

Godox

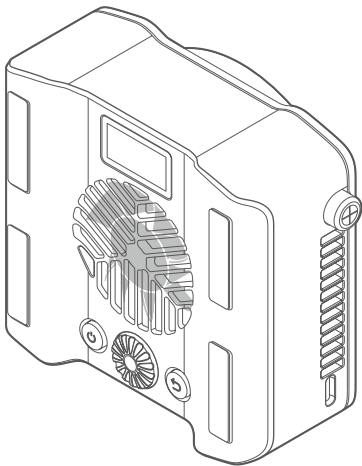

ML40Bi

使用手册

Instruction Manual V1.1

V1.00 固件/Firmware

重要安全说明

使用前请务必仔细阅读本手册，并严格遵守以下安全注意事项。

危险

- 若外壳出现开裂、变形、进液、异味或异常发热等情况，请立即停止使用。
- 仅限使用原厂配件，或经制造商明确推荐的配件；否则可能导致火灾、电击或人身伤害。
- 如果电池更换不当会有爆炸危险，只能用同样类型或等效类型的电池来更换，仅维修人员可更换，非一般人员更换。请勿拆卸产品或拆解电池。
- 电池不得暴露在诸如日照，火烤或类似过热环境中，产品不得淋雨、进水。
- 消费者若使用电源适配器充电，则应购买配套使用获得 CCC 认证并满足标准要求的电源适配器。
- 电池禁止拆解、撞击、挤压或投入火中。若出现严重鼓胀，请勿继续使用。请勿置于高温环境中。浸水后禁止使用。
- 使用时，应放置在易散热的地方，不要放置在床头、被褥上、包裹里或其他不易散热的环境中，避免婴幼儿接触玩耍，儿童请在成人指导下使用。

警告

- 本设备不具备防水防尘功能，禁止在雨天、高湿度、多尘环境中使用。
- 若设备进水或受潮，请立即切断电源，并断开所有连接线缆。
- 关机并断开所有线缆，存放在通风干燥、无强磁场干扰的环境中。
- 严禁在酒精、汽油等易燃易爆气体或溶剂附近使用本设备。
- 严禁覆盖散热孔。
- 严禁私自拆卸或改装设备。非授权拆解可能导致电路故障或永久性损坏。如需维修，请联系神牛授权服务中心。

请勿直视光源

物品清单

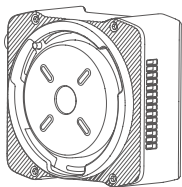

灯体 × 1

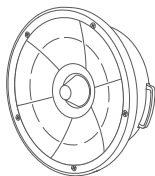

透镜反光杯 (ML-L10) × 1

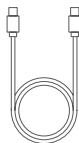

USB-C 充电线 × 1



使用手册 × 1

注:

1. 开箱后核对所购套装内的物品, 若有缺失或破损, 及时联系经销商。
2. 图示仅供参考, 具体以实际产品为准。

部件名称

1. 卡口释放键
2. 磁吸安装位
3. USB-C 接口
4. 模式 / 菜单 / 返回键
5. 1/4" 螺纹孔
6. 调节拨盘
7. 电源键
8. 显示屏
9. NFC 感应区

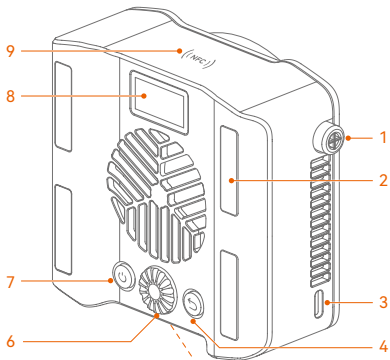

10. 神牛卡口
11. COB 灯珠
12. 散热孔

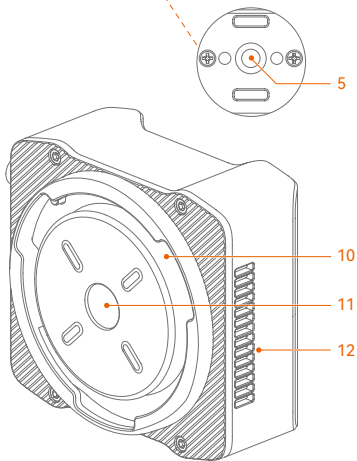

附件使用步骤

透镜反光杯: 安装时对准卡口推入, 顺时针旋转直至锁定。拆卸时按住卡口释放键, 同时逆时针旋转将其取下。

灯架 (另购): 将灯体 1/4" 螺纹孔对准灯架装入, 并旋紧固定钮。

磁吸安装: 将灯体背部吸附于铁质表面。

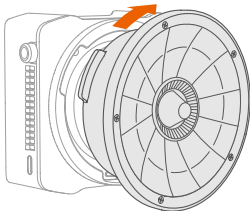

安装

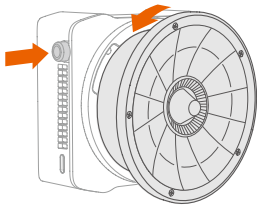

拆卸

基础操作说明

开机: 长按电源键。若已开启“防误触”功能, 请按提示转动拨盘解锁。

关机: 长按电源键直至显示屏熄灭。

充电: 通过 USB-C 接口连接 PD 60W 或以上充电器 (充满约 2.5 小时)。

按键与调节拨盘操作指南

模式 / 菜单 / 返回键: 短按进入模式与菜单界面, 或返回上一级。

调节拨盘: 短按确认选择或退出当前设置。

旋转切换选项或调节数值。

模式详解

CCT 模式

提供宽域色温调节。

亮度: 0%~100%

色温: 2800K~6500K

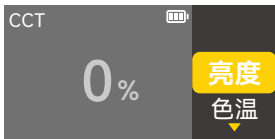

FX 模式

内置 11 类光效, 可模拟各种真实场景; 旋转调节拨盘进行选择, 选中后短按拨盘进入参数调节。

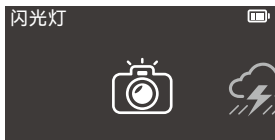

光效	亮度	色温	速度	其他
闪光灯	0% -100%	2800K-6500K	1-100	模式: 闪光灯 / 镁光灯 触发: 自动 / 手动
雷闪电		2800K-6500K	/	闪烁次数: 随机 /1-10 频率: 随机 /2-20 触发: 自动 / 手动
多云		/	随机 /1-100	亮暗比例: 30%-90%
坏灯泡		2800K-6500K	1-100	/
电视机		/	1-100	/
蜡烛		/	1-100	/
火		/	1-100	/
烟花		/	1-100	余烬: 1-100
爆炸		2800K-6500K	1-100	余烬: 1-100 触发: 自动 / 手动
焊接		2800K-6500K	1-100	/
SOS		2800K-6500K	/	/

注: 光效可设置开启或关闭; 触发方式设为手动时, 短按调节拨盘触发一次光效。

菜单设置与应用程序



蓝牙

支持开启 / 关闭蓝牙、执行连接重置及查看设备 MAC 地址。



风扇

静音: 关闭风扇以实现零噪音。高负载时系统将限制功率输出以防过热。

自动: 智能调速, 兼顾降噪与散热, 适配日常场景。

中速 / 高速: 固定转速增强散热, 建议高温或长时间满功率使用时选择。



防误触

关: 长按电源键开机后可直接进入主界面。

开: 长按电源键后, 需旋转拨盘进行解锁。可防止设备在存放或运输途中误触开启。



屏幕设置

调节显示屏亮度 (10%-100%)。

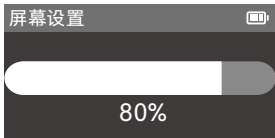

语言

选择界面语言: 简体中文 / English。

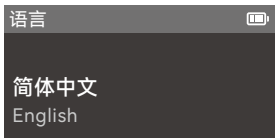

恢复出厂设置

确认后, 所有参数将还原至出厂默认值。
设备自动重启, 亮度重置为 100%。



灯具信息



“Godox Light” 应用程序连接指南

扫描右侧二维码，或在应用商店搜索“Godox Light”下载安装。

1. **蓝牙重置:** 进入 菜单 > 蓝牙 > 重置 并确认。
2. **蓝牙配对:** 打开应用程序，点击右上角“+”选择“蓝牙添加”，搜索并连接设备。
3. **NFC 速连:** 开启移动设备 NFC 功能，在应用程序内轻触“NFC 添加”，靠近灯具 NFC 感应区即可自动配对。



固件升级

进入应用程序，设备列表中点击 []，选择“固件升级”。将自动检测新版本，请按提示操作。

升级说明



设备连接蓝牙成功
后，从 app 进行升级

照度数据

色温	测试条件	照度单位	1m	2m	3m
2800K	裸灯	lux	775	204	100
		fc	72	19	9
	搭配透镜反光杯 ML-L10	lux	19400	4250	1730
		fc	1800	375	161
3200K	裸灯	lux	904	238	116
		fc	84	22	11
	搭配透镜反光杯 ML-L10	lux	22600	4960	2030
		fc	2100	461	188
4300K	裸灯	lux	975	257	125
		fc	91	24	12
	搭配透镜反光杯 ML-L10	lux	24200	5350	2190
		fc	2250	497	203
5600K	裸灯	lux	1060	280	136
		fc	99	26	13
	搭配透镜反光杯 ML-L10	lux	26400	5840	2390
		fc	2450	543	222
6500K	裸灯	lux	1130	298	145
		fc	105	28	13
	搭配透镜反光杯 ML-L10	lux	28000	6210	2550
		fc	2600	577	237

注: 文中数据均为 100% 亮度下的平均测试值。

技术参数

型号	ML40Bi
内置锂电池	3.63V / 4800mAh / 17.424Wh (*2PCS)
	充电时间 ≈ 2 小时 30 分钟
	满电续航 ≈ 42 分钟 (100% 亮度输出)
USB-C 接口	输入: 5V $\overline{=}$ 3A, 9V $\overline{=}$ 3A, 12V $\overline{=}$ 3A, 20V $\overline{=}$ 5A, 60W
亮度范围	0% ~ 100%
色温范围	2800K ~ 6500K
FX 光效	11 类
CRI	≈ 96
TLCI	≈ 96
控制方式	应用程序、灯体控制
蓝牙控制距离	最远 30 米
工作环境温度	-10°C ~ 40°C
尺寸 (不含透镜反光杯)	97 × 46 × 91mm
净重 (不含透镜反光杯)	≈ 422g

注: 产品设计与规格如有变更, 恕不另行通知。

维护保养

- 清洁前务必关机并断开电源。仅可使用干燥软布擦拭, 严禁使用酒精、苯或其他挥发性溶剂。
- 为延长电池寿命, 长期闲置时须每 3 个月进行维护性充电, 建议电量保持在 40% - 60%。

Important Safety Instructions

Read this manual thoroughly before use and strictly observe the following safety precautions.

DANGER

- Stop using the product immediately if the housing is cracked or deformed, if liquid enters the device, or if it emits a strange odor or becomes abnormally hot.
- Use only original Godox accessories or accessories specified by the manufacturer. Failure to do so may result in fire, electric shock, or personal injury.
- Danger of explosion if the battery are not replaced properly, danger of fire or explosion if replaced with the wrong type of battery pack, replace only with battery of the same type or equivalent. Battery replacement must be performed by authorized service personnel only. Do not disassemble the product or disassemble the battery.
- The battery must not be exposed to conditions such as sunlight, fire, or similar excessive heat. Do not expose to rain or water.
- When charging, use a power adapter that meets certified safety standards.
- The Battery is not allowed to be disassembled, hit, crushed or thrown into fire. Do not continue to use if it is seriously swollen. Do not place in a high temperature environment. Do not use after immersion in water.
- When using, it should be placed in a place where it is easy to dissipate heat, and should not be placed on the bedside, bedding, in a package or other environments that are not easy to dissipate heat. Keep out of contact with infants and young children, and children should use under adult guidance.

WARNING

- This device is NOT waterproof. Do not use in rain, high humidity, or dusty environments.
- If liquid enters the device or it becomes damp, disconnect the power immediately and remove all cables.
- Power off the device and disconnect all cables. Store in a dry, well-ventilated environment away from strong magnetic fields.
- Do not operate near flammable gases or liquids (e.g., alcohol, gasoline).
- Do not block ventilation areas.
- Do not disassemble or modify the device without authorization. Unauthorized disassembly may result in circuit malfunction or permanent damage. Contact an authorized Godox service center for repairs.

 **Do not stare at the operating light source.**

What's Inside

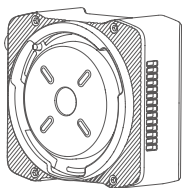

Light Fixture × 1

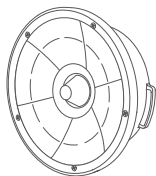

Lens Reflector (ML-L10) × 1

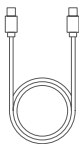

USB-C Charging Cable × 1



User Manual × 1

Note:

1. Check the package contents after unboxing. If any items are missing or damaged, contact the dealer immediately.
2. Illustrations are for reference only and may differ from the actual product.

Names of Parts

1. Mount Release Button
2. Magnetic Mount
3. USB-C Port
4. ⏪ MODE / MENU / RETURN Button
5. 1/4" Threaded Hole
6. Select Dial
7. ⏻ Power Button
8. Display
9. NFC Zone

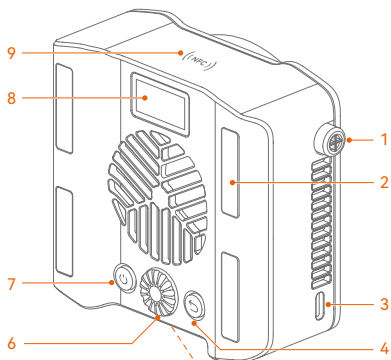

10. Godox Mount
11. LED COB
12. Air Intake / Vent

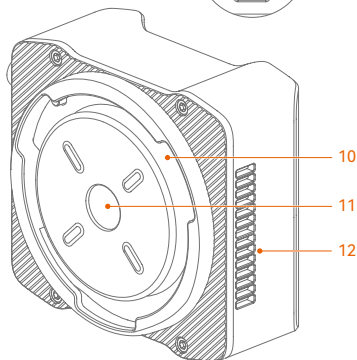

Accessory Installation

Lens Reflector: Align with the mount, insert, and rotate clockwise until it clicks into place. To remove, Long Press and hold the Mount Release Button and turn counter-clockwise.

Light Stand (Sold Separately): Mount the light onto a light stand via the 1/4" threaded hole, and tighten the locking knob.

Magnetic Mounting: Attach the back of the light to an iron surface.

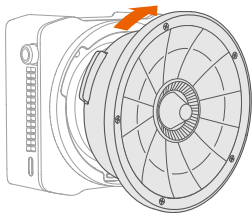

Install

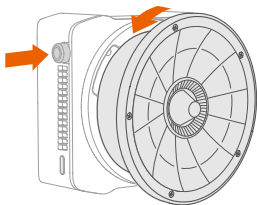

Remove

Basic Operation

Power On: Long Press the Power Button. If the "Anti-False Touch" is enabled, turn the Select Dial clockwise to unlock.

Power Off: Long Press the Power Button until the display turns off.

Charging: Connect the device to a power source using the included USB-C cable and a compatible power adapter (sold separately).

Button and Select Dial Operation

MODE / MENU / RETURN Button: Press to enter the Mode/Menu interface or return to the previous level.

Select Dial:

Press: Confirm a selection or exit the current setting.

Turn: Switch options or adjust values.

Lighting Modes

CCT Mode

Offers wide CCT range adjustment.

DIM: 0% - 100%

CCT: 2800K - 6500K

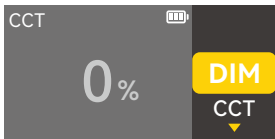

FX Mode (Lighting Effects)

11 built-in lighting effects simulate realistic scenarios. Turn the Select Dial to select an effect, then press the dial to adjust parameters.



Effect	DIM	CCT	Speed	Others
Flash	0% -100%	2800K-6500K	1-100	Mode: Camera Flash/Flash Bulb Trigger: Auto/Manual
Lightning		2800K-6500K	/	Times: Random/1-10 Frequency: Random/2-20 Trigger: Auto/Manual
Cloudy		/	Random/1-100	Ratio: 30% -90%
Broken Bulb		2800K-6500K	1-100	/
TV		/	1-100	/
Candle		/	1-100	/
Fire		/	1-100	/
Firework		/	1-100	Ember: 1-100
Explosion		2800K-6500K	1-100	Ember: 1-100 Trigger: Auto/Manual
Welding		2800K-6500K	1-100	/
SOS		2800K-6500K	/	/

Note: In "Manual" trigger mode, press the Select Dial to trigger the effect once.

Menu Settings and App

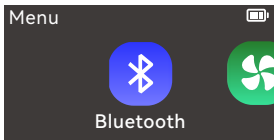

Bluetooth

Switch Bluetooth on or off, reset the connection, and view the MAC address.

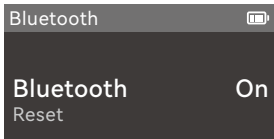

Fan Settings

Mute: Turns off the fan for silent operation. Power output will be limited during high loads to prevent overheating.

Auto: Intelligent speed adjustment that balances noise reduction and heat dissipation. Suitable for daily use.

Medium / High: Fixed fan speed for enhanced cooling. Recommended for high-temperature environments or long-term full-power operation.

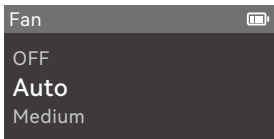

Anti-False Touch Setting

Off: The device powers on directly with a long press of the Power Button.

On: Requires a long press of the Power Button followed by the Select Dial rotation to unlock. This prevents accidental activation during storage or transport.

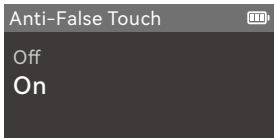

Display Settings

Adjust display brightness: 10% - 100%.

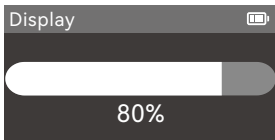

Language

Select interface language: 简体中文 > English.

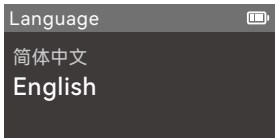

Factory Reset

Upon confirmation, all parameters will be restored to factory defaults. The device will reboot automatically, and brightness will reset to 100%.

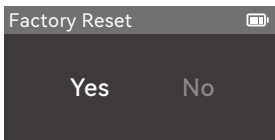

Fixture Info

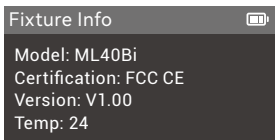

"Godox Light" App Connection Guide

Scan the QR code or search for "Godox Light" in the app store to download.

1. **Reset Bluetooth:** Menu > Bluetooth > Reset.
2. **Bluetooth Pairing:** Open the App. Tap "+" in the top right corner, select "Add Bluetooth", and connect the device.
3. **NFC Connection:** Enable NFC on the mobile device. Tap "Add NFC" in the App, then place the device near the NFC Zone on the light to pair automatically.



Firmware Upgrade

Tap the [] in the App device list and select "Firmware Upgrade". The App will automatically check for new versions. Follow the on-screen instructions.

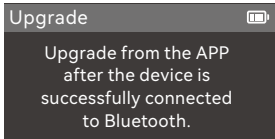

Illuminance Data

CCT	Testing Condition	Unit	1m	2m	3m
2800K	Bare Light	lux	775	204	100
		fc	72	19	9
	With Lens Reflector ML-L10	lux	19400	4250	1730
		fc	1800	375	161
3200K	Bare Light	lux	904	238	116
		fc	84	22	11
	With Lens Reflector ML-L10	lux	22600	4960	2030
		fc	2100	461	188
4300K	Bare Light	lux	975	257	125
		fc	91	24	12
	With Lens Reflector ML-L10	lux	24200	5350	2190
		fc	2250	497	203
5600K	Bare Light	lux	1060	280	136
		fc	99	26	13
	With Lens Reflector ML-L10	lux	26400	5840	2390
		fc	2450	543	222
6500K	Bare Light	lux	1130	298	145
		fc	105	28	13
	With Lens Reflector ML-L10	lux	28000	6210	2550
		fc	2600	577	237

Note: The data above are average values measured at 100% brightness.

Technical Data

Model	ML40Bi
Battery	3.63V / 4800mAh / 17.424Wh (+2PCS)
	Charging Time \approx 2 hours 30 minutes
	Runtime \approx 42 minutes (at 100% Brightness)
USB-C Input	5 V \equiv 3 A, 9 V \equiv 3 A, 12 V \equiv 3 A, 20 V \equiv 5 A, 60 W
Brightness Range	0% ~ 100%
CCT Range	2800K ~ 6500K
FX Modes	11 Types
CRI	\approx 96
TLCI	\approx 96
Control Methods	App Control / On-board Control
Bluetooth Distance	Max. 30m
Working Environment	-10°C ~ 40°C
Dimensions	3.82" \times 1.81" \times 3.58" (excluding reflector)
Net Weight	\approx 422g (excluding reflector)

Note: Specifications and data may subject to changes without notice.

Maintenance

- Power off and disconnect the power supply before cleaning. Use a dry, soft cloth only. Strictly do not use alcohol, benzene, or other volatile solvents.
- To extend battery life, perform a maintenance charge every 3 months during long-term storage. It is recommended to keep the battery level at 40% - 60%.

FCC Caution

This device complies with part 15 of the FCC Rules. Operation is subject to the following two conditions:

- (1) This device may not cause harmful interference, and
- (2) this device must accept any interference received, including interference that may cause undesired operation.

Any Changes or modifications not expressly approved by the party responsible for compliance could void the user's authority to operate the equipment.

Note: This equipment has been tested and found to comply with the limits for a Class B digital device, pursuant to part 15 of the FCC Rules. These limits are designed to provide reasonable protection against harmful interference in a residential installation. This equipment generates uses and can radiate radio frequency energy and, if not installed and used in accordance with the instructions, may cause harmful interference to radio communications. However, there is no guarantee that interference will not occur in a particular installation. If this equipment does cause harmful interference to radio or television reception, which can be determined by turning the equipment off and on, the user is encouraged to try to correct the interference by one or more of the following measures:

- Reorient or relocate the receiving antenna.
- Increase the separation between the equipment and receiver.
- Connect the equipment into an outlet on a circuit different from that to which the receiver is connected.
- Consult the dealer or an experienced radio/TV technician for help.

The device has been evaluated to meet general RF exposure requirement. The device can be used in portable exposure condition without restriction. The use distance is not more than 5mm.

IC Warning

This device complies with Innovation, Science and Economic Development Canada licence-exempt RSS standard(s). Operation is subject to the following two conditions:

- (1) This device may not cause interference, and
- (2) This device must accept any interference, including interference that may cause undesired operation of the device.

Cet appareil est conforme aux normes RSS exemptées de licence d'Innovation, Sciences et Développement économique Canada. L'exploitation est soumise aux deux conditions suivantes:

- (1) Cet appareil ne peut pas causer d'interférences, et
- (2) Cet appareil doit accepter toute interférence, y compris celles qui pourraient entraîner un fonctionnement accidentel de l'appareil.

Any Changes or modifications not expressly approved by the party responsible for compliance could void the user's authority to operate the equipment.

Tout changement ou modification non expressément approuvé par la partie responsable de la réglementation de l'OCDE peut faire perdre à l'utilisateur le droit d'utiliser l'appareil.

Note: This equipment has been tested and found to comply with the limits for a Class B digital device, pursuant to part 15 of the FCC Rules. These limits are designed to provide reasonable protection against harmful interference in a residential installation. This equipment generates uses and can radiate radio

frequency energy and, if not installed and used in accordance with the instructions, may cause harmful interference to radio communications. However, there is no guarantee that interference will not occur in a particular installation. If this equipment does cause harmful interference to radio or television reception, which can be determined by turning the equipment off and on, the user is encouraged to try to correct the interference by one or more of the following measures:

- Reorient or relocate the receiving antenna.
- Increase the separation between the equipment and receiver.
- Connect the equipment into an outlet on a circuit different from that to which the receiver is connected.
- Consult the dealer or an experienced radio/TV technician for help.

Remarque: cet appareil a été testé pour répondre aux limites des appareils numériques de classe B conformément à la partie 15 des règles de la Federal Communications Commission des États - Unis. Ces limites sont conçues pour fournir une protection raisonnable contre les interférences nuisibles dans les installations résidentielles. L'appareil génère de l'énergie RF utilisée et rayonne, ce qui peut causer des interférences nocives pour les communications radio s'il n'est pas installé et utilisé conformément aux instructions. Cependant, aucune Garantie contre les interférences dans une installation spécifique. Si l'appareil cause des interférences nuisibles à la réception de la radio ou de la télévision, qui peuvent être déterminées en éteignant et en allumant l'appareil, l'utilisateur est encouragé à tenter de corriger les interférences par une ou plusieurs des mesures suivantes:

- redirection ou repositionnement de l'antenne de réception.
- augmenter l'espacement entre l'appareil et le récepteur.
- Connecter l'appareil à une prise sur un circuit différent de celui auquel le récepteur est connecté.
- consultez votre revendeur ou un technicien radio / tv expérimenté pour obtenir de l'aide.

RF warning for Portable device:

The device has been evaluated to meet general RF exposure requirement. The device can be used in portable exposure condition without restriction.

Avertissement RF pour les appareils portables:

L'appareil a été évalué pour répondre aux exigences générales d'exposition aux radiofréquences. Équipement Peut être utilisé sans restriction dans des conditions d'exposition portables.

Warning

Operating frequency: 2402MHz – 2480MHz (BT)

Maximum EIRP Power: 5dBm

Declaration of Conformity

GODOX Photo Equipment Co., Ltd. hereby declares that this equipment are in compliance with the essential requirements and other relevant provisions of Directive 2014/53/EU. In accordance with Article 10(2) and Article 10(10), this product is allowed to be used in all EU member states. For more information of DoC, Please click this web link: <https://www.godox.com/eu-declaration-of-conformity/>

The device complies with RF specifications when the device used at 0mm from your body.

产品保修

尊敬的用户, 本保修卡是申请保修服务的重要凭证, 请您配合销售商填写并妥善保管, 谢谢!

产品信息	型号	产品条形码
用户信息	姓名	联系电话
	通信地址	
销售商信息	名称	
	联系电话	
	通信地址	
	销售日期	
备注		

注: 此表应由销售商盖章确认。

产品信息

本文件适用于相关《产品保修信息》(见后面说明)所列产品, 其他非属此范围的产品或部件(如促销品、赠品及其他出厂后附加的部件等)不在此保修承诺内。

保修期

产品及部件的相应保修期按相关的《产品保修信息》执行。保修期自产品首次购买日起算, 购买日以购买产品时保修卡登记日期为准。

如何获得保修服务

您可直接与产品销售商或授权服务机构联系, 也可拨打神牛产品售后服务电话, 与我们联系, 由我们的服务人员为您安排服务。申请保修时, 您应提供有效的保修卡作为保修凭证, 方可获得保修。如您不能提供有效的保修卡, 则在我们确认产品或部件属于保修范围的情况下, 也可以为您提供保修, 但这不作为我们的义务。

不适用保修情况

如产品存在下列情况,本文件项下的保证和服务将不适用:①产品或部件超出保修期;②因不当使用、维护或保管导致的损坏,如:不当搬运;未按产品合理预期用途使用;不当插拔外接设备;跌落或外力挤压;接触或暴露于不适当温度、溶剂、酸碱、水浸或潮湿环境;③非神牛授权机构或人员安装、修理、更改、添加或拆卸导致的损坏;④产品或部件原有识别信息被修改或删除;⑤无有效保修卡;⑥使用非合法授权、非标准或非公开发行的软件导致的损坏;⑦因不可抗力或意外事故导致的损坏;⑧其他非产品本身质量问题导致的故障或损坏。遇上述情况,您应向相关责任方寻求解决,神牛对此不承担任何责任。不在保修期或保修范围内的部件、附件或软件导致产品不能正常使用的,不是保修范围内的故障。产品使用过程中正常的脱色,磨损和消耗,不是保修范围内的故障。

产品保修和服务支持信息

产品的保修期和服务类型按以下《产品保修信息》执行:

部件	保修期(月)	保修服务类型
内部电路板	12	客户送修
其他(例如光效附件、各类线材或其他包装)	无	无保修

神牛产品售后服务电话 0755-29609320-8062

Warranty

Dear customers, as this warranty card is an important certificate to apply for our maintenance service, please fill in the following form in coordination with the seller and safe-keep it. Thank you!

Product Information	Model	Product Code Number
Customer Information	Name	Contact Number
	Address	
Seller Information	Name	
	Contact Number	
	Address	
	Date of Sale	
Note		

Note: This form shall be sealed by the seller.

Applicable Products

The document applies to the products listed on the Product Maintenance Information (see below for further information). Other products or accessories (e.g. promotional items, giveaways and additional accessories attached, etc.) are not included in this warranty scope.

Warranty Period

The warranty period of products and accessories is implemented according to the relevant Product Maintenance Information. The warranty period is calculated from the day (purchase date) when the product is bought for the first time, and the purchase date is considered as the date registered on the warranty card when buying the product.

How to Get the Maintenance Service

If maintenance service is needed, you can directly contact the product distributor or authorized service institutions. You can also contact the Godox after-sale service call and we will offer you service. When applying for maintenance service, you should provide valid warranty card. If you cannot provide valid warranty card, we may offer you maintenance service once confirmed that the product or accessory is involved in the maintenance scope, but that shall not be considered as our obligation.

Inapplicable Cases

The guarantee and service offered by this document are not applicable in the following cases:

① **The product or accessory has expired its warranty period;** ② **Breakage or damage caused by inappropriate usage, maintenance or preservation, such as improper packing, improper usage, improper plugging in/out external equipment, falling off or squeezing by external force, contacting or exposing to the improper temperature, solvent, acid, base, flooding and damp environments, etc;** ③ **Breakage or damage caused by non-authorized institution or staff in the process of installation, maintenance, alternation, addition and detachment;** ④ **The original identifying information of product or accessory is modified, alternated, or removed;** ⑤ **No valid warranty card;** ⑥ **Breakage or damage caused by using illegally authorized, nonstandard or non-public released software;** ⑦ **Breakage or damage caused by force majeure or accident;** ⑧ **Breakage or damage that could not be attributed to the product itself.** Once met these situations above, you should seek solutions from the related responsible parties and Godox assumes no responsibility. The damage caused by parts, accessories and software that beyond the warranty period or scope is not included in our maintenance scope. The normal discoloration, abrasion and consumption are not the breakage within the maintenance scope.

Maintenance and Service Support Information

The warranty period and service types of products are implemented according to the following Product Maintenance Information:

Parts	Maintenance Period (month)	Warranty Service Type
Internal circuit board	12	Customer sends the product to designated site
Other items (optical accessories, cables, package, etc)	No	Without warranty

Godox After-sale Service Call **0755-29609320-8062**



Wechat
Official Account
神牛微信公众号

制造商：深圳市神牛摄影器材有限公司

地址：深圳市宝安区福海街道塘尾社区耀川工业区厂房 2 栋

电话：+86-755-29609320 (8062) 传真：+86-755-25723423

邮箱：godox@godox.com 网址：godox.com

MANUFACTURER: GODOX Photo Equipment Co., Ltd.

Add.: Building 2, Yaochuan Industrial Zone, Tangwei Community, Fuhai Street,

Bao'an District, Shenzhen 518103, China Tel: +86-755-29609320 (8062)

Fax: +86-755-25723423 E-mail: godox@godox.com Website: godox.com



合格证
QC PASS

Copyright © 2026 Godox All Rights Reserved.

中国制造 Made in China | 705-ML40B0-01